

A95

APEX SERIES SHOT BLASTER

OPERATING MANUAL



Read Manual Before Operating Machine

402306 Rev F

Table of Contents

Table of Contents	3
Features and Specifications	4
Safety	6
General Rules for Safe Operation	6
Shot Blaster Safety Guidelines	7
Recommended Electrical Practices	8
Components and Assembly	10
Handle Assembly	10
Moving the Machine Around the Jobsite	10
Operating Controls.....	10
Blast Wheel Drive	11
Separator	11
Shot Valve.....	11
Magnets and Brushes	11
Airflow	12
Shot Selection.....	12
Operation	13
Adding Shot	13
Cleaning Out the Hopper Tray	13
Preparing for Operation	13
Start-Up Procedure.....	14
Blast Pattern	14
Working Direction	15
Travel Speed.....	15
Adjusting the Height of Magnets and Brushes.....	16
Turning Off the Machine	17
Emergency Stop	17
Storage	17
Troubleshooting Guide	18
General Errors	18
Electrical Errors	19
Warranty	20

Features and Specifications



FEATURES

Dual-Function Control Lever - Turns blast wheel motor ON/OFF and controls shot feed. Located on push handle for reduced fatigue.

Adjustable Handle - Greatly reduces operator fatigue.

8" Blast Pattern - Allows a blasting capacity up to 400 ft²/hr.

Air Wash System - A superior in-line air wash separation system maximizes the separation of dust from the reclaimed shot resulting in prolonged part life.

Rear-Facing Vacuum Port - Improves airflow during operation.

Front Swivel Casters - Front swivel casters increase maneuverability and control.

Dustless - Operates virtually dust free when connected to a dust collector.

Curved Rebound Plenum - Allows for more efficient shot flow and removal of dust and debris.

Features and Specifications

Product Specifications						
Width	Length	Height	Weight	Working Width	Blasting Capacity	Power
12" (30.5 cm)	45" max. (114.3 cm) 37" min (94.0 cm)	41" max. (104.1 cm) 34" min. (86.4 cm)	121 lbs (54.9 kg)	8" (20.3 cm)	Up to 400 ft ² /hr	1.5 HP (1.12 kW)

Machine Variants			
Region	Serial Number	Max. Amps	Input Power
Domestic (North America)	A95-10XXXX	17A	120V / 60 Hz
International	A95-11XXXX	12A	230V / 50 Hz
	A95-20XXXX	16A	110V / 50 Hz

Recommended Dust Collector: DL2000 or other with 200 CFM minimum rating

Safety

GENERAL RULES FOR SAFE OPERATION

Before use, anyone operating or performing maintenance on this equipment must read and understand this manual, as well as any labels packaged with or attached to the machine and its components. Read the manual carefully to learn equipment applications and limitations, as well as potential hazards associated with this type of equipment. Keep manual near machine at all times. If your manual is lost or damaged, contact National Flooring Equipment (NFE) for a replacement.

Personal

Dress properly and use safety gear.

Do not wear loose clothing; it may be caught in moving parts. Anyone in the work area must wear safety goggles or glasses and hearing protection. Wear a dust mask for dusty operations. Hard hats, face shields, safety shoes, etc. should be worn when specified or necessary.

Maintain control; stay alert.

Keep proper footing and balance, and maintain a firm grip. Observe surroundings at all times. Do not use when tired, distracted, or under the influence of drugs, alcohol, or any medication that may cause decreased control.

Keep hands away from all moving parts and tooling.

Wear gloves when changing tooling. Remove tooling when machine is not in use and/or lower cutting head to the floor.

Do not force equipment.

Equipment will perform best at the rate for which it was designed. Excessive force only causes operator fatigue, increased wear, and reduced control.

Environment

Avoid use in dangerous environments.

Do not use in rain, damp or wet locations, or in the presence of explosive atmospheres (gaseous fumes, dust, or flammable materials). Remove materials or debris that may be ignited by sparks. Keep work area tidy and well-lit - a cluttered or dark work area may lead to accidents.

Protect others in the work area and be aware of surroundings.

Provide barriers or shields as needed to protect others from debris and machine operation. Children and other bystanders should be kept at a safe distance from the work area to avoid distracting the operator and/or coming into contact with the machine. Operator should be aware of who is around them and their proximity. Support personnel should never stand next to, in front of, or behind the machine while the machine is running. Operator should look behind them before backing up.

Guard against electric shock.

Ensure that machine is connected to a properly grounded outlet. Prevent bodily contact with grounded surfaces, e.g. pipes, radiators, ranges, and refrigerators. When scoring or making cuts, always check the work area for hidden wires or pipes.

Maintenance & Repairs

Begin maintenance work only when the machine is shut down, unplugged, and cooled down.

Use proper cleaning agents.

Ensure that all cleaning rags are fiber-free; do not use any aggressive cleaning products.

Schedule regular maintenance check-ups.

Ensure machine is properly cleaned and serviced. Remove all traces of oil, combustible fuel, or cleaning fluids from the machine and its connections and fittings. Retighten all loose fittings found during maintenance and repair work. Loose or damaged parts should be replaced immediately; use only NFE parts.

Do not weld or flame-cut on the machine during repairs, or make changes to machine without authorization from NFE.

Equipment

Use proper parts and accessories.

Only use NFE-approved or recommended parts and accessories. Using any that are not recommended may be hazardous.

Ensure accessories are properly installed and maintained.

Do not permanently remove a guard or other safety device when installing an accessory or attachment.

Inspect for damaged parts.

Check for misalignment, binding of moving parts, loose fasteners, improper mounting, broken parts, and any other conditions that may affect operation. If abnormal noise or vibration occurs, turn the machine off immediately. Do not use damaged equipment until repaired. Do not use if power switch does not turn machine on and off. For all repairs, insist on only identical NFE replacement parts.

Maintain equipment and labels.

Keep handles dry, clean, and free from oil and grease. Keep cutting edges sharp and clean. Follow instructions for lubricating and changing accessories. Motor and switches should be completely enclosed at all times with no exposed wiring. Inspect cord regularly. Labels carry important information; if unreadable or missing, contact NFE for a free replacement.

Avoid accidental starting; store idle equipment.

When not in use, ensure that the machine is unplugged; do not turn on before plugging in. Store in a dry, secured place. Remove tooling when storing, and keep away from children.

SHOT BLASTER SAFETY GUIDELINES

Before use, anyone operating this equipment must read and understand these safety instructions.

Shot Blasting

Beware of hidden obtrusions.

Watch out for hidden dangers and protrusions in flooring. Do not use on largely uneven surfaces.

Avoid contact with hot shroud.

Do not touch the shroud without proper hand protection. Both become hot during operation and remain hot after stopping the machine.

Provide barriers, shields, or safety glasses as needed to protect others from debris.

Use for correct applications.

Do not force equipment to do heavier duty work than it was made for.

Use a magnetic sweep immediately after blasting.

Steel shot that is left on the walking surfaces creates a slipping hazard which could cause unexpected falls.

Dust Collection

Turn off machine before working with dust collector.

Do not switch off or remove the dust collector while the machine is running.

Use with appropriate dust collecting system.

Do not operate machine designed for use with a dust collector without the dust collector. Ensure dust collector is on and operating properly while grinding.

Dispose of collected waste.

Do not leave the dust collector bag full of waste. Handle and dispose of bag and waste in accordance with all applicable local, state, and federal regulations. The dust bin of a connected dust collector must be emptied before transportation.



WARNING: GRINDING/CUTTING/DRILLING OF MASONRY, CONCRETE, METAL AND OTHER MATERIALS CAN GENERATE DUST, MISTS AND FUMES CONTAINING CHEMICALS KNOWN TO CAUSE SERIOUS FATAL INJURY OR ILLNESS, SUCH AS RESPIRATORY DISEASE, CANCER, BIRTH DEFECTS OR OTHER REPRODUCTIVE HARM. IF YOU ARE UNFAMILIAR WITH THE RISKS ASSOCIATED WITH THE PARTICULAR MATERIAL BEING CUT, REVIEW THE MATERIAL SAFETY DATA SHEET AND/OR CONSULT YOU EMPLOYER,

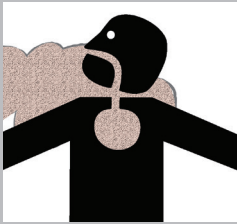

THE MATERIAL MANUFACTURER/SUPPLIER, GOVERNMENTAL AGENCIES SUCH AS OSHA AND NIOSH AND OTHER AUTHORITIES ON HAZARDOUS MATERIALS. CALIFORNIA AND SOME OTHER AUTHORITIES, FOR INSTANCE, HAVE PUBLISHED LISTS OF SUBSTANCES KNOWN TO CAUSE CANCER, REPRODUCTIVE TOXICITY, OR OTHER HARMFUL EFFECTS. CONTROL DUST, MIST AND FUMES AT THE SOURCE WHERE POSSIBLE. IN THIS REGARD USE GOOD WORK PRACTICES AND FOLLOW THE RECOMMENDATIONS OF THE MANUFACTURER/SUPPLIER, OSHA/NIOSH, AND OCCUPATIONAL AND TRADE ASSOCIATIONS. WHEN THE HAZARDS FROM INHALATION OF DUST, MISTS AND FUMES CANNOT BE ELIMINATED, THE OPERATOR AND ANY BYSTANDERS SHOULD ALWAYS WEAR A RESPIRATOR APPROVED BY OSHA/MSHA FOR THE MATERIAL BEING CUT.

Safety

RECOMMENDED ELECTRICAL PRACTICES



WARNING: ELECTRICAL CORDS CAN BE HAZARDOUS. MISUSE CAN RESULT IN FIRE OR DEATH BY ELECTRICAL SHOCK. READ CAREFULLY AND FOLLOW ALL DIRECTIONS.



CAUTION: ALWAYS FOLLOW APPLICABLE ELECTRICAL CODES, STANDARDS AND/OR REGULATIONS. CONSULT YOUR LOCAL ELECTRICAL AUTHORITY OR A LICENSED ELECTRICIAN BEFORE ATTEMPTING TO MODIFY AN ELECTRICAL INSTALLATION. ENSURE THAT CIRCUIT AND GROUND FAULT PROTECTION DEVICES AND ALL OTHER ELECTRICAL SAFETY EQUIPMENT ARE FUNCTIONING PROPERLY.

Guidelines for Using Extension Cords

- Ensure the cord type is suitable for the application and location. If you are unsure about your cord type, consult a qualified electrical professional or electrician.
- Ground your equipment. The equipment must be plugged into an appropriate outlet, one which is properly installed and grounded in accordance with all codes and ordinances. Do NOT modify the plug provided with the equipment. Never remove the grounding prong from the plug.
- Do not remove, bend or modify any metal prongs or pins of the plug. Modifications to power cords and/or plugs may result injury and/or equipment damage.
- FULLY INSERT plug into outlet.
- Do not use excessive force to make connections.
- Never unplug by pulling the cord from the outlet. Pull plug rather than cord to reduce the risk of damage.
- Regularly examine your extension cord and ensure it is in good electrical condition. Never use a damaged cord—either replace it or have it repaired by a qualified person.
- Protect your extension cords from sharp objects, excessive heat and damp or wet areas. Keep the cord away from oil, cutting edges and moving parts.
- Do not drive, drag or place objects over cord.
- Avoid overheating. Uncoil cord and do not cover it with any material.
- Avoid accidental starting. Be sure equipment is turned off before plugging in. Do not use equipment if the power switch does not turn the equipment on and off.
- Make sure equipment is not running before disconnecting cord.
- Unplug equipment. When not in use and before changing accessories or performing maintenance, unplug the machine.

Extension Cord Selection

All cords should be sized appropriately to reduce the risk of damage, fire or reduced performance. Reference the table in this section for recommended cord sizes.

RECOMMENDED ELECTRICAL PRACTICES—CONTINUED

How to Use This Table

1. Determine your supply voltage.
2. Determine the total length of your cord including all extension cords.
3. Determine the maximum amp draw for your machine.
4. Trace your voltage across the top of the table to the first length that is greater than or equal to your cord length.
5. Follow the column down to the first row that contains a maximum amp draw greater than or equal to yours.
6. This cell contains the minimum recommended wire size for your application.

Example

Application: Max Amps = 11A, Length = 40ft, Voltage = 120V

Solution: 40ft is between the 25ft and 50ft columns, so the larger of the two columns is chosen. Likewise, 11A is between the 10A and 12A rows, so the larger of the two rows is chosen. 14 AWG (2.5mm²) is the minimum recommended wire size for this example.

Single Phase Equipment				
Max Length	120V Supply	25ft (7.5m)	50ft (15m)	75ft (22.5m)
	230V Supply	50ft (15m)	100ft (30m)	150ft (45m)
Max Amps		Minimum Wire Size		
8	16 AWG (1.5mm ²)	16 AWG (1.5mm ²)	16 AWG (1.5mm ²)	16 AWG (1.5mm ²)
10	16 AWG (1.5mm ²)	16 AWG (1.5mm ²)	16 AWG (1.5mm ²)	16 AWG (1.5mm ²)
12	14 AWG (2.5mm ²)	14 AWG (2.5mm ²)	14 AWG (2.5mm ²)	14 AWG (2.5mm ²)
14	14 AWG (2.5mm ²)	14 AWG (2.5mm ²)	14 AWG (2.5mm ²)	14 AWG (2.5mm ²)

Recommended Extension Cord Sizes

Single Phase Equipment							
Max Length	120V Supply	25ft (7.5m)	50ft (15m)	75ft (25m)	100ft (30m)	150ft (45m)	200ft (60m)
	230V Supply	50ft (15m)	100ft (30m)	150ft (45m)	200ft (60m)	300ft (90m)	400ft (120m)
Max Amps		Minimum Wire Size					
8	16 AWG (1.5mm ²)	16 AWG (1.5mm ²)	16 AWG (1.5mm ²)	16 AWG (1.5mm ²)	16 AWG (1.5mm ²)	14 AWG (2.5mm ²)	14 AWG (2.5mm ²)
10	16 AWG (1.5mm ²)	16 AWG (1.5mm ²)	16 AWG (1.5mm ²)	16 AWG (1.5mm ²)	16 AWG (1.5mm ²)	14 AWG (2.5mm ²)	12 AWG (4mm ²)
12	14 AWG (2.5mm ²)	14 AWG (2.5mm ²)	14 AWG (2.5mm ²)	14 AWG (2.5mm ²)	14 AWG (2.5mm ²)	12 AWG (4mm ²)	12 AWG (4mm ²)
14	14 AWG (2.5mm ²)	14 AWG (2.5mm ²)	14 AWG (2.5mm ²)	14 AWG (2.5mm ²)	14 AWG (2.5mm ²)	12 AWG (4mm ²)	10 AWG (6mm ²)
16	14 AWG (2.5mm ²)	14 AWG (2.5mm ²)	14 AWG (2.5mm ²)	14 AWG (2.5mm ²)	14 AWG (2.5mm ²)	12 AWG (4mm ²)	10 AWG (6mm ²)
18	14 AWG (2.5mm ²)	14 AWG (2.5mm ²)	14 AWG (2.5mm ²)	12 AWG (4mm ²)	12 AWG (4mm ²)	12 AWG (4mm ²)	10 AWG (6mm ²)
20	12 AWG (4mm ²)	12 AWG (4mm ²)	12 AWG (4mm ²)	12 AWG (4mm ²)	12 AWG (4mm ²)	10 AWG (6mm ²)	10 AWG (6mm ²)
25	12 AWG (4mm ²)	12 AWG (4mm ²)	12 AWG (4mm ²)	12 AWG (4mm ²)	12 AWG (4mm ²)	10 AWG (6mm ²)	8 AWG (10mm ²)
30	10 AWG (6mm ²)	10 AWG (6mm ²)	10 AWG (6mm ²)	10 AWG (6mm ²)	10 AWG (6mm ²)	8 AWG (10mm ²)	8 AWG (10mm ²)

Note: The table is based on a <10% voltage loss, data from the U.S. National Electrical Code Tables 400.5(A) & 400.5(B) and typical resistances for copper wire.

Components and Assembly

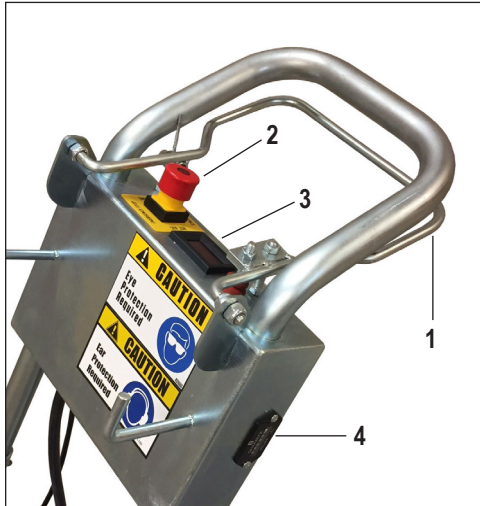

FIG. 1

HANDLE ASSEMBLY

The machine comes with the handle disassembled. To assemble the handle, complete the following:

1. Insert handle into handle frame and align holes in desired position.
2. Insert the two pull-out pins.



CAUTION: THE HANDLE IS ONLY FIXED WITH TWO PULL-OUT PINS AND CANNOT BE USED AS A LIFTING POINT FOR HOISTING.

MOVING THE MACHINE AROUND THE JOBSITE

When the machine is not used for blasting and being moved around the jobsite, keep the machine tilted back so the front caster is about 4-8" (10-20mm) off the floor. Moving the machine using the rear wheels helps to keep the magnets from picking up debris.

Note: Do not squeeze the control lever when moving the machine or the shot valve will open and shot will drop on the floor.



CAUTION: WHEN MOVING MACHINE, DO NOT DROP ON REAR WHEELS AS THIS COULD CAUSE THEM TO GO OUT OF ADJUSTMENT.

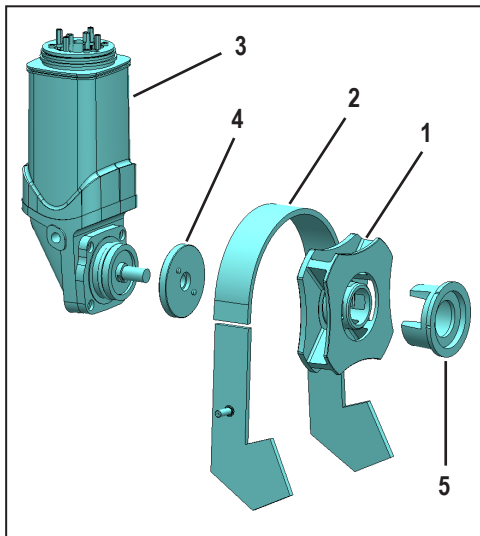

FIG. 2

OPERATING CONTROLS (FIGURE 1)

Control Lever (1)

The control lever controls the blast wheel motor and shot feed. Slightly squeezing the lever starts the blast wheel motor. Continuing to slowly squeeze the control lever gradually opens the shot valve allowing shot to flow to the blast wheel. Maximum feed occurs with the lever completely squeezed.

Slowly releasing the control lever gradually closes the shot valve, decreasing the shot feed. Fully releasing the lever closes the valve and stops the motor.

Emergency Stop Switch (2)

In case of an emergency push the emergency stop switch to stop the blast wheel motor. To release the emergency stop switch, twist the red button and pull it upwards.

Ammeter (3)

The ammeter shows the load consumption of the blast wheel motor. The reading will increase as the control lever is squeezed. See *Features and Specifications* for the maximum amp ratings.

Hour Meter (4)

The hour meter displays the actual working hours performed by the blast wheel.

BLAST WHEEL DRIVE (FIGURE 2)

The blast wheel (1) throws shot at the surface to be treated. It is surrounded by replaceable liners (2) and is driven by an electric motor (3) via the wheel hub (4). Shot is fed to the blast wheel through the feed spout.

Components and Assembly

The position of the control cage (5) determines the direction shot is thrown to the surface and the evenness of the blast pattern.

SEPARATOR (FIGURE 3)

The separator (1) is mounted inside the cover (2) and separates the shot from dust. Shot is returned back into the hopper (3), while the dust is fed through the dust hose connection (4) to the dust collector.

A removable mesh tray (5) is positioned on the top of the hopper to prevent coarse contaminants from getting to the blast wheel.

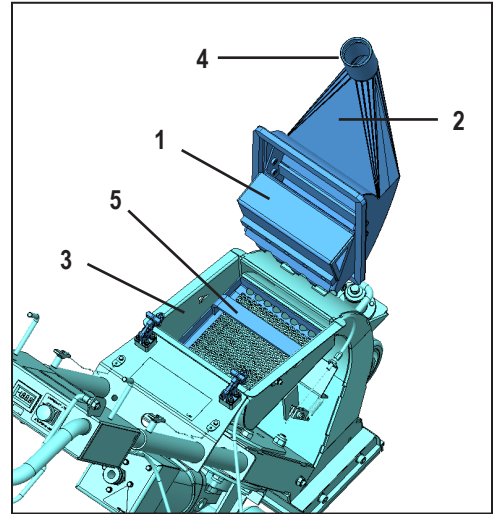

FIG. 3

SHOT VALVE (FIGURE 4)

The shot valve (1) regulates the flow of shot to the blast wheel and is located between the hopper (2) and the feed spout (3). The valve is controlled by the control lever via the control cable (4).

MAGNETS AND BRUSHES (FIGURE 5)

The magnets and brushes regulate the airflow inside the machine. Magnets (1) are located on the front and sides of the blast opening and are surrounded by brushes (2). The rear side has a brush only. Airflow enters the machine through the rear brush (3) and travels through the rebound channel transporting shot and dust upwards.

The correct height adjustment is .25-.32" (6-8 mm) from the bottom of the magnets to the surface and is important for optimum machine performance. In general, the magnets should be set at the maximum height of .32" (8 mm) for very rough surfaces and set at the minimum height of .25" (6 mm) for very smooth surfaces. See *Adjusting the Height of Magnets and Brushes* for the adjustment procedure.

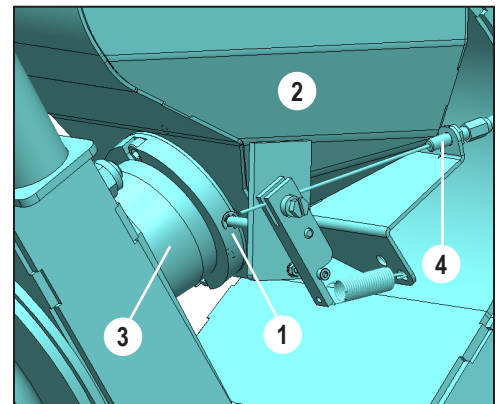

FIG. 4

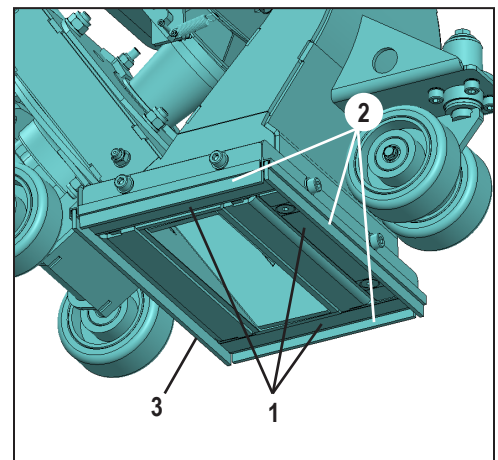

FIG. 5

Components and Assembly

AIRFLOW (FIGURE 6)

The following illustration shows the airflow through the machine.

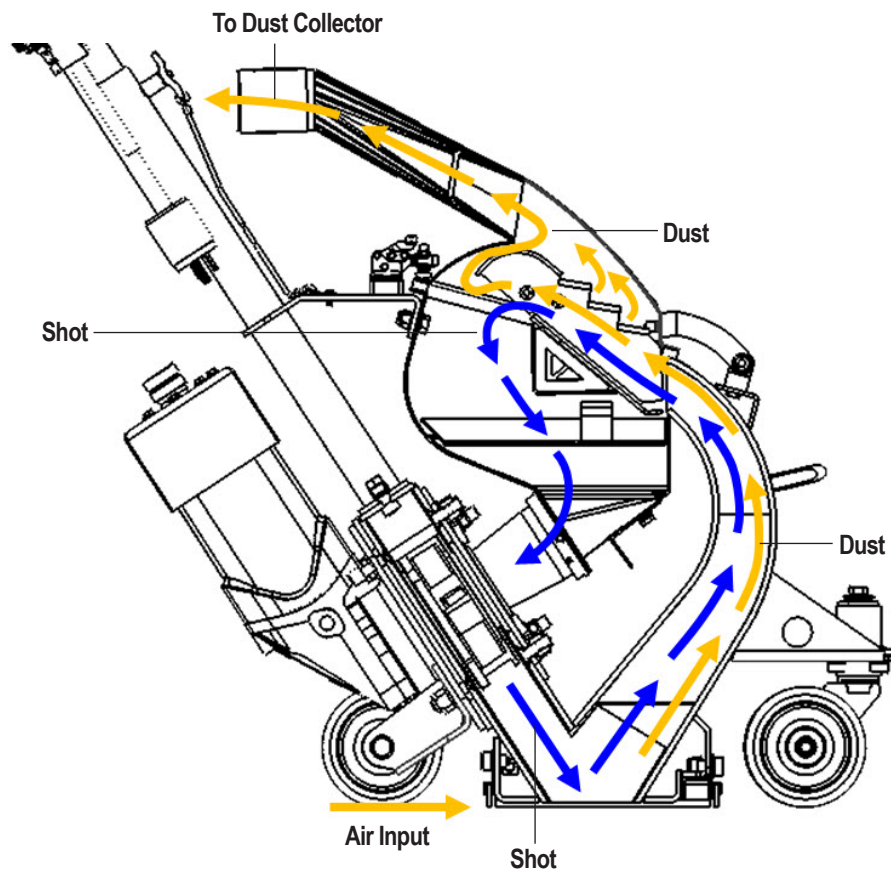

FIG. 6

SHOT SELECTION

Selection of shot is important, as this is the material that profiles the surface. The use of incorrect shot increases wear on the machine. Contact NFE customer service regarding the best shot to use for your application.

S280 Shot (Approx. Size: .028")

Often used when the surface is to be sealed afterwards.

Applications:

- Creating fine profiles on surfaces such as vacuum concrete and non-glazed tiles
- Removing thin layers of paint

S330 Shot (Approx. Size: .033")

Applications:

- Creating a fine to medium texture on concrete
- Removing glazing from tiles prior to sealing with anti-skid coating
- Removing old impregnations and coatings about .04" (1 mm) thick



WARNING: BEFORE PERFORMING MAINTENANCE, ALWAYS DISCONNECT THE MACHINE FROM POWER TO PREVENT ACCIDENTAL START-UP.

ADDING SHOT (FIGURE 7)

1. Ensure the control lever is fully released and the shot valve is closed.
2. Release the clamps (1), then open the cover (2).
3. Fill the hopper (3) with shot to a level just below the mesh tray (4).
4. Close the cover and secure it with the clamps.

CLEANING OUT THE HOPPER TRAY (FIGURE 7)

1. Release the clamps (1), then open the cover (2).
2. Remove the mesh tray (4) from the hopper and empty the debris.
3. Replace the tray.
4. Close the cover and secure the clamps.

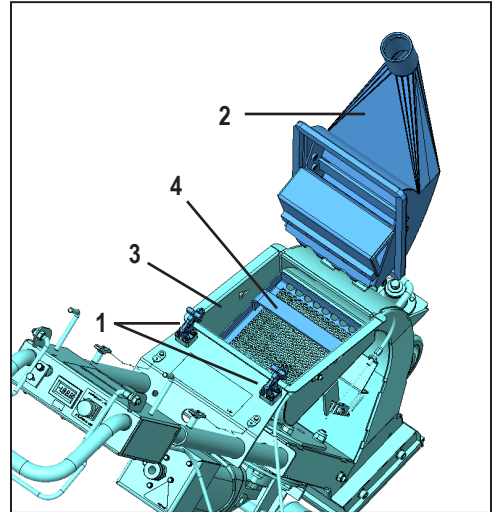

FIG. 7

PREPARING FOR OPERATION

Complete the following before start-up:

- Ensure all protective covers are attached correctly.
- Check that all parts are assembled correctly.
- Check that all fasteners are tight.
- Check parts for damage and wear; replace if necessary.
- Make sure the hopper is free of debris and that the shot valve functions properly.
- Check the level of shot in the hopper; fill if necessary.
- It is important to operate the dust collector on a separate circuit from the shot blaster. The shot blaster needs the full amp draw to operate effectively.
- Check that the dust collector is connected correctly and all hose connections are tight.
- Empty dust collector container.
- Check that the magnet height is approximately .25-.32" (6-8 mm) from surface. See *Adjusting the Height of Magnets and Brushes* for the adjustment procedure.
- Sweep surface for loose parts prior to operation. Ensure that machine can travel over all inequalities on the surface; small inequalities like weld seams or floor joints are not an issue.
- Run magnetic sweep over surface to remove any metallic debris.
- Preload the magnets—Place a small amount of shot on the floor in front of the machine and push the machine back and forth over the shot until gone to create a seal.

Note: Whenever the machine is not used for blasting, the shot valve must be closed.

Operation

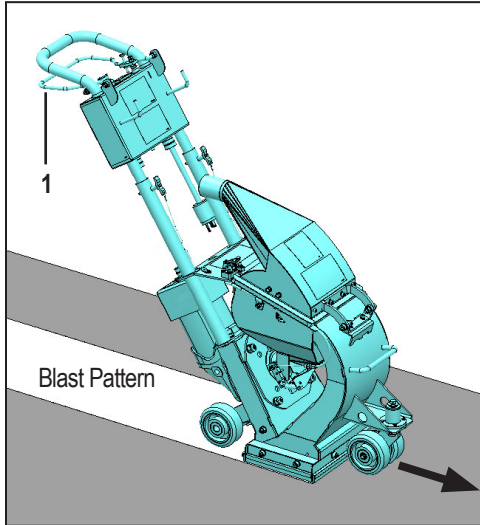

FIG. 8

START-UP PROCEDURE (FIGURE 8)

1. Turn on the dust collector.
 2. Release the emergency stop switch by twisting the red button and pulling it upwards.
- Note:** The ammeter illuminates when the machine is connected to power and the emergency stop switch is released.
3. Squeeze the control lever (1) slightly to start the blast wheel motor and allow the motor to reach a steady state.
 4. With the blast motor running, push the machine forward. Once the machine is moving, slowly squeeze the control lever. This will start to open the shot valve so shot can flow to the blast wheel.

Note: The ammeter reading will increase as the control lever is squeezed. See Features and Specifications for the maximum amp ratings.

5. Continue to slowly push the machine forward and watch the blasted area carefully. If necessary, change the travel speed to achieve the desired profile.



WARNING: DO NOT TILT BACK THE MACHINE WHILE BLASTING. TILTING MACHINE WILL CAUSE SHOT TO SPRAY OUT AND COULD CAUSE INJURY.



CAUTION: WHEN BLASTING CONCRETE OR ASPHALT, ONLY OPEN THE SHOT VALVE WHEN THE MACHINE IS MOVING. IF THE MACHINE IS NOT MOVING AND THE VALVE IS OPENED, DEEP HOLES WILL BE BLASTED INTO THE SURFACE WITHIN SECONDS.



CAUTION: EMPTY THE DUST COLLECTOR REGULARLY.

BLAST PATTERN (FIGURE 9)

When blasting the surface, material should be removed within the whole width of the blast opening and the blast pattern should be even.

The direction shot is thrown to the surface and the evenness of the blast pattern is determined by the position of the control cage. If the machine produces a one-sided, uneven blast pattern, the control cage must be readjusted. See this machine's service manual for the adjustment procedure. The correct adjustment of the control cage is crucial in achieving an even blast pattern.

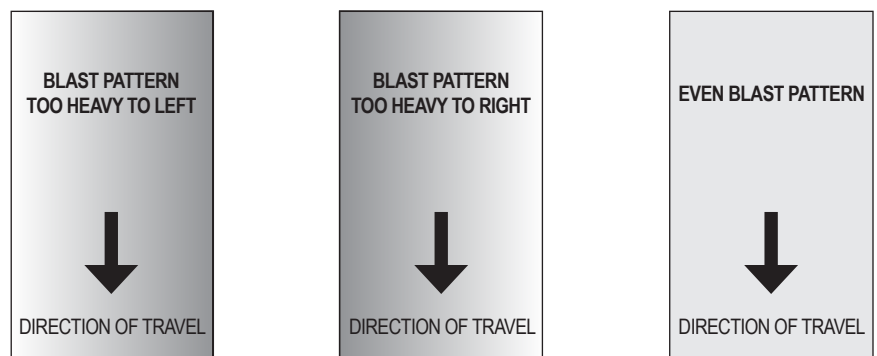

FIG. 9

WORKING DIRECTION (FIGURE 10)

1. Carry out blasting in parallel back-and-forth tracks working away from the dust collector. Make sure the power cord and dust hose do not become twisted. Keep an eye on the maximum cord and hose lengths and reposition if needed.
2. When the end of a track is reached, slightly release the control lever to close the shot valve while keeping the motor running. Turn the machine around by swinging the front end in a loop going forward.

Note: When turning the machine around, do NOT back up. Rather, swing the front end in a loop going forward to prevent losing the bottom shot seal and causing the front caster to swivel backwards.

3. Align the machine for the next track, squeeze control lever to open the shot valve and proceed to blast the new track with minimal overlapping.
4. Repeat this process to complete the surface, moving away from the dust collector to the unblasted surface. When finished, move the dust collector to the completed surface and blast the area where the dust collector was located.

Note: If a fine blasting result is required, it is necessary to blast in the same direction.

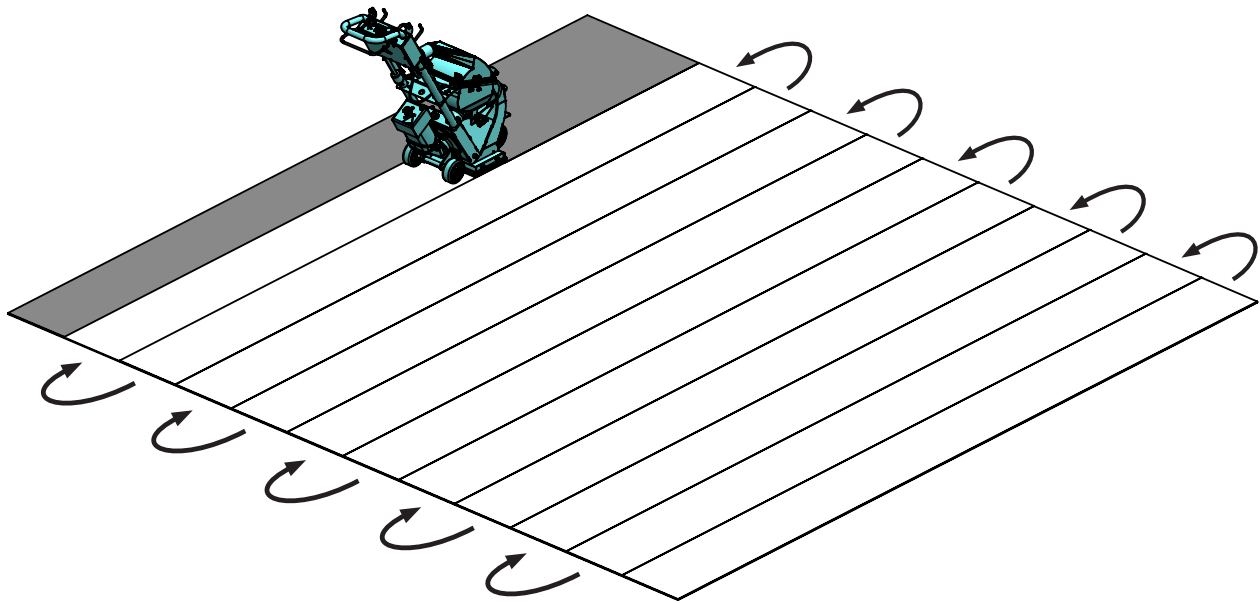
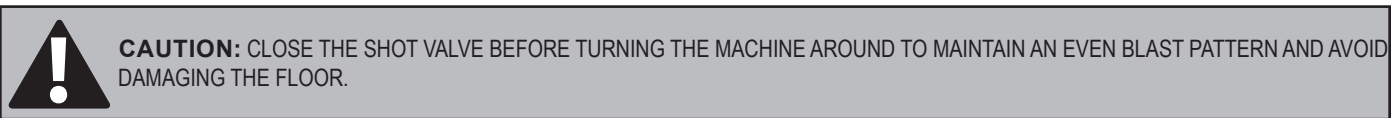

FIG. 10

TRAVEL SPEED

Selecting the right travel speed is important for achieving a good blasting result and depends on the type of surface material and desired profiling. Determine the right travel speed by observing the blasted surface and varying the travel speed during operation.

- Slight profiling on concrete requires a higher travel speed than coarse profiling.
- Blasting on steel requires a very low travel speed of the machine.

Operation



WARNING: BEFORE PERFORMING MAINTENANCE, ALWAYS DISCONNECT THE MACHINE FROM POWER TO PREVENT ACCIDENTAL STARTUP.

ADJUSTING THE HEIGHT OF MAGNETS AND BRUSHES (FIGURE 11)

The correct height adjustment of the magnets is .25-.32" (6-8 mm) and is important for regulating airflow through the machine and creating a good seal. The magnets should be set at the maximum height of .32" (8 mm) for very rough surfaces. For very smooth surfaces the magnets should be set at the minimum height of .25" (6 mm).

1. Remove the front and side brushes from the machine.
2. Tip the machine up and scrape the shot from the magnets using a putty knife or similar tool.



WARNING: DO NOT USE YOUR BARE HANDS TO REMOVE SHOT FROM MAGNETS. STAPLES, NAILS OR OTHER SHARP OBJECTS THAT MAY HAVE BEEN PICKED UP DURING USE COULD CAUSE INJURY.

3. Loosen the nuts of the rear wheel bracket and adjust the bracket so the bottom of the magnets are .25-.32" (6-8 mm) above the floor.
4. Retighten the nuts.
5. Replace the front and side brushes flush with the floor.
6. Rear brush height should be .125" (3 mm) from floor.

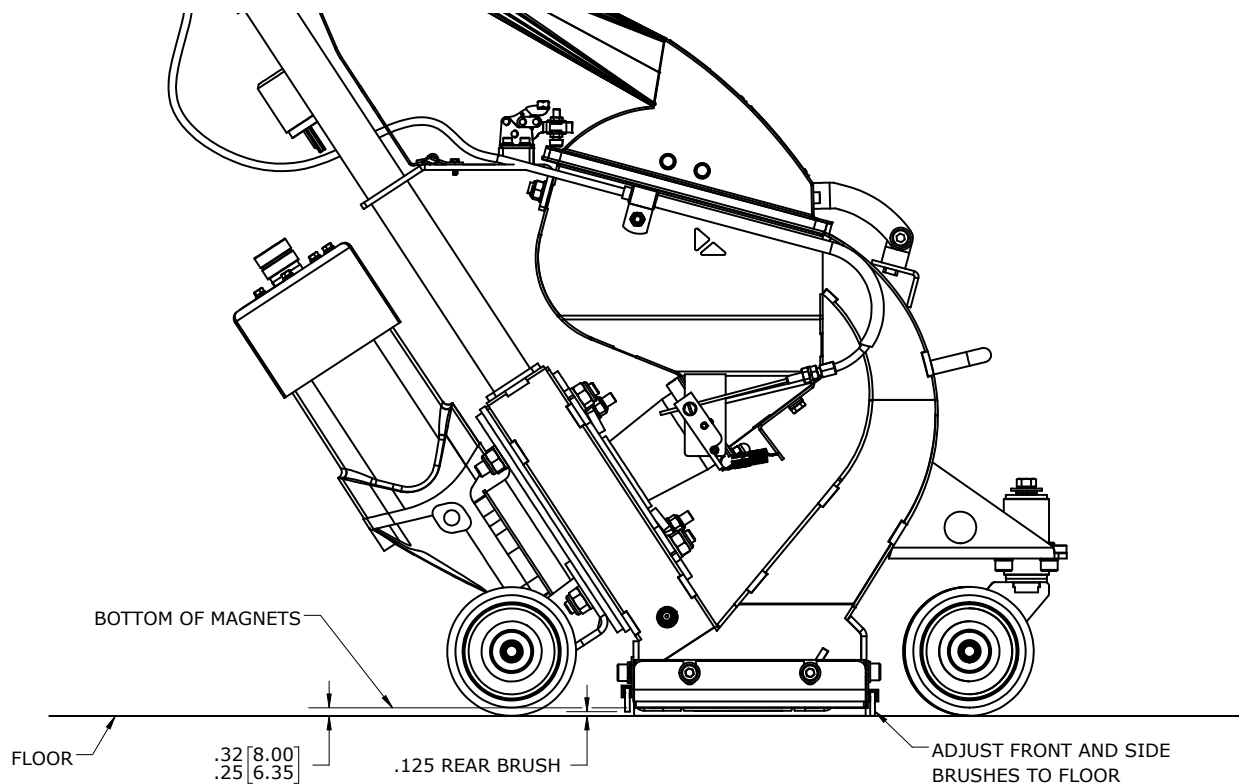

FIG. 11

TURNING OFF THE MACHINE (FIGURE 12)

1. Slowly release the control lever (1) so it returns to the starting position. The shot valve will close and the blast wheel motor will stop after a few seconds.
2. Continue pushing the machine forward until shot stops flowing to the blast wheel. This prevents holes from being blasted into the floor while the machine is being turned off.
3. Make sure all turning parts of the machine have stopped. Unplug the machine from the power source.
4. Push down the emergency stop switch (2) to avoid starting the machine unexpectedly.
5. Turn off dust collector.



FIG. 12

EMERGENCY STOP (FIGURE 12)

In case of emergency you can immediately stop the machine by pushing the emergency stop switch (2).

To release the emergency stop switch, twist the red button and pull it upwards.

STORAGE

Before storing the machine for a long period, complete the following:

1. Remove all shot from the machine. It is effective to use the dust collector hose to vacuum out the hopper.
2. Scrape shot from the magnets using a putty knife or similar tool.



WARNING: DO NOT USE YOUR BARE HANDS TO REMOVE SHOT FROM MAGNETS. STAPLES, NAILS OR OTHER SHARP OBJECTS THAT MAY HAVE BEEN PICKED UP DURING USE COULD CAUSE INJURY.

3. Clean the machine.
4. Store the machine in a dry area.
5. Cover the machine.

Troubleshooting Guide

GENERAL ERRORS

Problem	Cause	Solution
Unusual vibrations or noise	Control cage not centered.	Center control cage.
	Blast wheel installed incorrectly.	Check pin on wheel hub.
	Loose blast wheel nut.	Replace and/or tighten nut.
	Wheel hub worn out.	Replace wheel hub.
	Unbalance due to broken blast wheel blade.	Replace blast wheel. Check inside of machine and remove broken blade.
	Worn motor bearings or shaft.	Replace motor.
	Uneven wear of blast wheel.	Replace blast wheel.
Reduced or no performance	Not enough shot in hopper.	Add shot.
	Insufficient shot fed to blast wheel.	Clean mesh tray. Check valve for blockage.
	Loose valve lever.	Tighten set screw to secure lever to flapper.
	Valve out of adjustment.	Reset the amperage to factory spec.
	Too much dust in hopper.	Check dust collector filters and replace if needed. Purge more frequently. Verify CFM rating of dust collector is sufficient.
	Blast wheel or control cage is worn out.	Replace worn parts.
	Valve does not close properly.	Clear valve of debris.
	Too much shot fed when turned on.	Ensure motor reaches a steady state before opening the valve.
	Travel speed is too fast.	Reduce travel speed to achieve desired profile.
Dropping shot	Too much dust in shot hopper.	Check filters and size of dust collector (CFM).
		Concrete is too soft, building up too much dust in hopper.
	Separator cover is not sealed.	Check cover seal for air leaks. Adjust cover position or replace seal.
	Shot hopper is over-filled.	Remove excess shot to level just below the mesh tray.
	Magnet height out of adjustment.	Verify magnet height is not above .32 (8 mm).
	Control cage not rotated correctly.	Adjust control cage to achieve even blast pattern.
	Blast wheel worn.	Replace blast wheel.
	Liners worn.	Replace liners.
Magnets lost field.	Replace magnets.	
Losing shot	Shot being sucked out of vacuum port.	Use a smaller dust collector or reduce suction and flow.
Too much dust present	Insufficient air flow towards dust collector.	Verify CFM rating of the dust collector is sufficient (200 CFM minimum rating).
		Check all seals and dust hoses.
		Check dust collector filters and replace if needed. Purge more frequently.

Troubleshooting Guide

ELECTRICAL ERRORS

Problem	Cause	Solution
Motor does not start. Motor stops during operation.	Emergency stop is depressed.	Release emergency stop button.
	Circuit breaker tripped.	Make sure dust collector and shot blaster are connected on separate circuits.
		Make sure you are using an appropriately sized circuit for the amperage requirements.
		Reset the amperage to factory spec.
	Ground fault related failure.	Ensure ground fault protection device is functioning properly.
	Cord unplugged.	Plug in cord.
	Wires damaged.	Check wires, replace if needed.
	Faulty switch or relays.	Contact NFE customer support for service.
Motor is damaged.	Contact NFE customer support for service.	



WARNING: BEFORE PERFORMING MAINTENANCE, ALWAYS DISCONNECT THE MACHINE FROM POWER TO PREVENT ACCIDENTAL START-UP.

Warranty

National Flooring Equipment Inc. (referred to as "The Company") warrants that each new unit manufactured by The Company to be free from defects in materials and workmanship in normal use and service for a period of twelve (12) months from date of shipment from The Company to the end user. If shipment to end user is from a Distributor, The Company may honor warranty for up to 15 months from initial shipment from the Company if the end user can provide documentation of receipt date. Accessories or equipment furnished and installed on the product by the Company but manufactured by others, including but not limited to: engines, motors, electrical components, transmissions etc., shall carry the accessory manufacturers own warranty. Battery warranties are prorated over the warranty period. Customer is responsible for the inspection of equipment or parts upon delivery. **Freight damages are excluded from this warranty.**

The Company, at its determination of defect, will repair or replace any product or part deemed to be defective in material or workmanship within specified warranty time period. All product determinations and / or repairs will take place at The Company repair facility or at a certified warranty location designated by The Company. The Company will coordinate and be responsible for all freight expenses associated with valid warranty claims. Freight and shipping expenses associated with abuse or misuse will be back charged to the Distributor/Customer. The Company reserves the right to modify, alter or improve any part / parts without incurring any obligation to replace any part / parts previously sold without such modified, altered or improved part / parts. In no event shall the seller or manufacturer of the product be liable for special, incidental, or consequential damages, including loss of profits, whether or not caused by or resulting from the negligence of seller and / or the manufacturer of the product unless specifically provided herein. **This warranty shall not apply to any products or portions there of which have been subjected to abuse, misuse, improper installation or operation, lack of recommended maintenance, electrical failure or abnormal conditions, and to products which have been tampered with, altered, modified, repaired, reworked by anyone not approved or authorized by the Company or used in any manner inconsistent with the provisions of the above or any instructions or specifications provided with or for the product.** Any and all unauthorized onsite warranty work conducted by unauthorized personnel or any outside person(s), is not covered by The Company unless the work has been pre-authorized by a predetermined manufacturer representative. This warranty excludes wearable parts and/or consumables.

Defective or failed material or equipment shall be held at the purchaser's premises until authorization has been granted by The Company to return or dispose of defective products. Products returned to The Company for inspection must be returned with a manufacturer authorized Return Material Authorization (RMA), and must be packaged to The Company's specifications to avoid damage during shipment. Any unauthorized return of equipment will be declined at the dock by The Company. Any non-approved items returned with approved returned items are subject to rejection and will not be credited. Credit will be issued for material found to be defective upon The Company's inspection based on prices at time of purchase.

TO OBTAIN SERVICE CONTACT NATIONAL FLOORING EQUIPMENT, INC. TOLL FREE AT 800-245-0267 FOR A REPAIR AUTHORIZATION NUMBER. COD FREIGHT RETURNS WILL NOT BE ACCEPTED. FREIGHT COLLECT SHIPMENTS WILL NOT BE ACCEPTED. WARRANTY REPAIRS MUST BE ACCOMPANIED BY DATE OF PURCHASE RECEIPT AND A RETURN/ REPAIR AUTHORIZATION NUMBER.

RETURN/REPAIR AUTHORIZATION NUMBER: _____

MACHINE SERIAL NUMBER: _____



Made in America Since 1968

9250 Xylon Avenue N • Minneapolis, MN 55445 • U.S.A.
Toll-free 800-245-0267 • Phone 763-315-5300 • Fax 800-648-7124 • Fax 763-535-8255
Web Site: www.nationalequipment.com • E-Mail: info@nationalequipment.com